



Fire protection solutions
for the printing industry

Safe for certain.

mx BRANDBEVEILIGING

RECOGNISING RISKS

Printing plants, with their entire company processes focused on punctual delivery to their customers, cannot afford to make any compromises when it comes to fire protection. Whether they use offset, relief, gravure or screen printing machines, if sources of ignition in the production process are not already detected in the origination phase and nipped in the bud, the result can be a devastating fire. The company may be insured against interruptions in production, but there is no replacement for lost customers and market shares. The protection of human life and of facilities therefore necessitates the use of special fire protection systems, which are exactly adapted to the required process technology.



Fire risks in the printing industry

- ▶ Use of flammable materials
- ▶ Formation of explosive concentrations of colorants and solvents
- ▶ Heating of printed material in the machine by mechanical friction heat from
 - ▶ fast-moving parts or in the drying process
 - ▶ Static electricity in connection with flammable colorants or solvents
- ▶ Deposits of colorants, synthetic or paper in the machine and in ventilation and exhaust ducts



Minimax provides reliable fire protection

The fire protection concept for printing machines focuses on an extremely fast responding fire extinguishing system that

automatically detects critical fire hazards and fights burgeoning fires with argon or carbon dioxide. Parallel to the extinguishing process, it initiates important control actions,

e.g. to interrupt the supply of colorants or material, to switch off machines and drying systems, and to activate the alarm organization.

CONCEPT

RELIABLE ALL-ROUND FIRE PROTECTION

Areas of application

- ▶ Printing units
- ▶ Drying and exhaust systems
- ▶ Folding machines
- ▶ Paint and paper warehouses
- ▶ Entire machine areas within the noise protection encapsulation



Complete solutions from Minimax fulfill high standards: availability, successful fire extinguishing and uninterrupted operation of the fire protection system.

EXTINGUISHING

FAST AND EFFECTIVELY

Argotec® fire extinguishing system

The extinguishing agent – argon or carbon dioxide – is stored either in high-pressure steel cylinders, which are combined in special racks with a suspension system to form an extinguishant unit, or in low-pressure vessels, if the protection scheme requires large quantities of extinguishant. In the event of a fire, the extinguishing process is released and controlled automatically.

The pipe network with extinguishing nozzles ensures fast buildup of the extinguishant concentration in the protected area. The burgeoning fire is extinguished before it can cause major damage. A volume protection system is used for encapsulated machines. Normally, individual system components of large printing machines are protected by a local protection system, which directs the extinguishant at the fire source by means of

local protection nozzles. After the fire has been extinguished, the printing machine is soon ready for operation again, since the use of argon or carbon dioxide as an extinguishant leaves no residue behind and the extinguishant is returned to the atmosphere by means of ventilation. After the fire has been extinguished, all that remains is to replenish the extinguishant supply.

Advantages of the Argotec® inert gas extinguishing technology

- ▶ Fast fire fighting without extinguishant residue
- ▶ Minimization of interruptions in production without impairment of machine functionality
- ▶ No damage to electric and electronic devices
- ▶ Economical and readily available extinguishant
- ▶ Efficient fire fighting for non-encapsulated machines
- ▶ No significant temperature decrease caused by extinguishant
- ▶ Direct discharge at printing unit
- ▶ Economical modular system
- ▶ Compact system saves space
- ▶ Approved and certified quality
- ▶ Maximum safety, also for the environment



SAFETY

A DANGER FORESEEN IS HALF AVOIDED

Fire detection

The high concentration of solvents means that open flames can be expected during out-break of the fire. Automatic early detection is ensured by flame or heat differential maximum detectors that are arranged in the danger zones. In combination, these two systems ensure high sensitivity and reliability in addition to maximum elimination of false alarms. For manual release, push-button units are provided on the machine control panel and near the escape routes. As soon as a detector detects a fire, the fire alarm panel initiates the shut-down of the printing machines, activates visual and acoustic alarms that display the danger status and activates the extinguishing system. The machine operator can initiate follow-up extinguishing at any time.

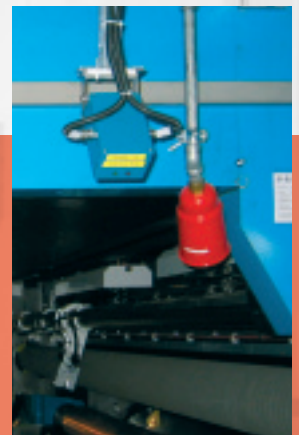
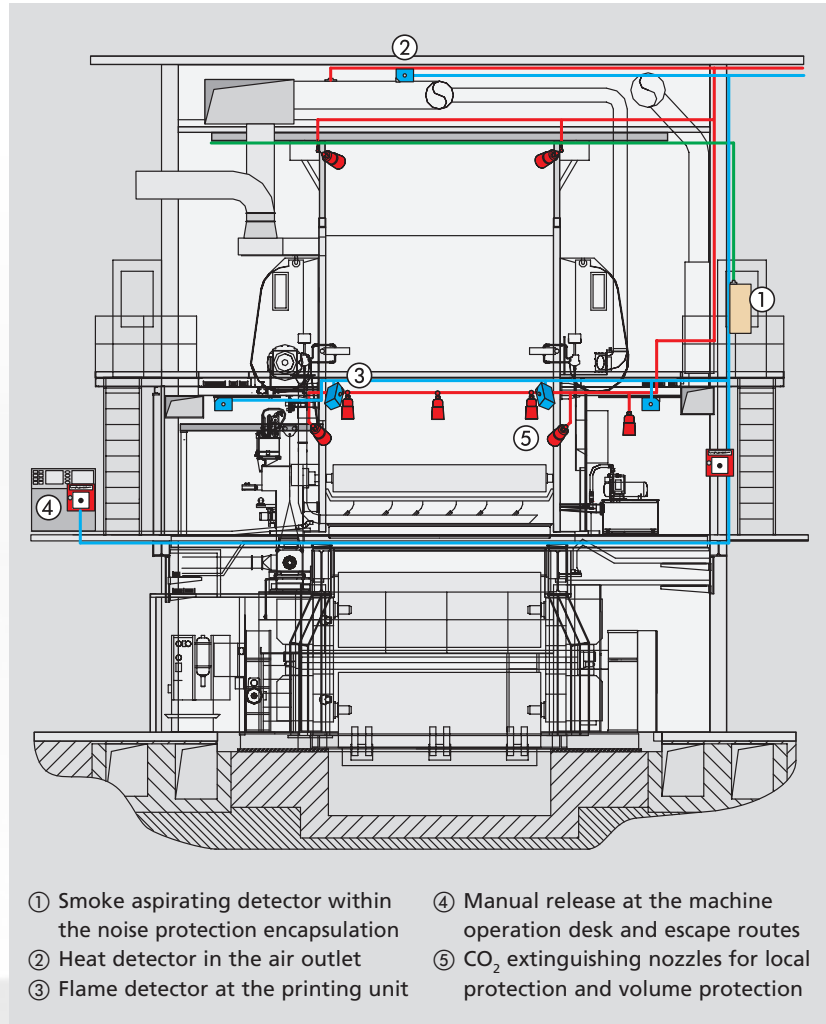

SOLUTIONS

RISK-RELATED FIRE PROTECTION

For larger applications, the combination of local protection and volume protection systems optimizes the fire protection scheme. "Fast extinguishing" by the local protection system extends directly to the immediately affected printing unit and extinguishes the fire using only very little extinguishant. Only if the fire escalates, the volume protection system is then automatically activated in the second stage. Due to its volume, the extinguishant supply can be stored in liquid state in a space-saving low-pressure vessel for larger applications requiring this combination of local and volume protection systems.



Compact extinguishing systems

For smaller printing machines, the compact extinguishing system is recommended for local protection. In this system, all function-relevant components are combined in a single unit with various function and accommodated in a cabinet, where they are protected from dust and moisture and mechanical damage: The system is made up of a rack with freely suspended extinguishing gas cylinders, including weighing devices with an electronically monitored loss indicator and an electromagnetic extinguishant release, in addition to a fire alarm and control panel integrated in the front door that is connected with the detectors, which react to heat or smoke, for activation of the extinguishing unit in the event of a fire.



MX-Brandbeveiliging B.V.
Televisieweg 62
NL-1322 AM Almere
Tel.: +31 (0) 36 54 61 600
Fax.: +31 (0) 36 54 61 610
E-Mail: info@mx-brandbeveiliging.nl
www.mx-brandbeveiliging.nl



Nr. S 89201

* Certified acc. to
ISO 9001