



Fire Protection for Catering Kitchens
KS 2000 Compact Extinguishing System

Safe for certain.

mx BRANDBEVEILIGING

RISKS

IDENTIFYING

Catering kitchens tend to use large quantities of hot fat and oil for the preparation of food. These fats and oils pose a particularly high fire risk.

Most fires in kitchens start in deep fryers, frying pans and grilling plates with defective overheating protection.

Fat self-ignites at a temperature of 350 °C, which is easily reached, and fat fires tend to spread very quickly. On many occasions, flames up to two metres high occurred only 30 seconds after the fire had started.

Attempts to extinguish such fires with water lead to devastating fat explosions. Using CO₂ extinguishers and fire blankets is often unsuccessful, and these devices are now prohibited by the trade associations in Germany and probably in all other countries for the extinguishing of fat fires. Kitchen fires can only be fought effectively with a specially developed extinguishant.

Every fire puts lives at risk and threatens the livelihood of people. Without effective fire extinguishing systems, you also risk huge damage to property. In many cases, extensive refurbishment is necessary, and your restaurant or canteen must close for a considerable period of time. In the worst case, you might even be forced out of business.



The KS 2000 compact extinguishing system has been specifically designed for use in catering kitchens. The fire detection elements respond the moment the first small

flame occurs, and the fire is promptly extinguished before serious damage can occur.

The Febramax-S extinguishant used in the system works in

two ways: It is sprayed through fine nozzles onto the equipment, forming a blocking layer over the fat or oil so that the fire is starved of oxygen.

SOLUTION

EXTINGUISHING FIRES SAFELY AND TWICE AS EFFECTIVELY

Simultaneously, the fat is cooled down by the water contained in the agent, so preventing self-ignition. The KS 2000 is thus twice as effective and reliable as conventional extinguishers. The integrated NC switch ensures

that all kitchen appliances are switched off instantly, preventing renewed self-ignition.

The specially developed Febramax-S agent is hygienically harmless and its residue can easily be cleaned off, so

that your kitchen is up and running again after only a short time. With a pH of 9.4, Febramax-S combines outstanding efficiency with least harm to health and the environment.



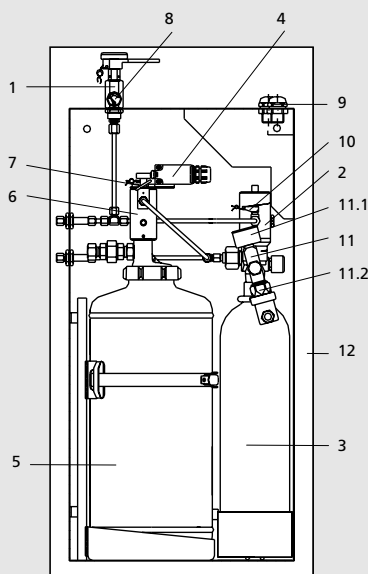

- 1 Manual actuation
- 2 Control valve
- 3 Control cylinder
- 4 Limit switch (4 A, 230 V AC, IP 67)
- 5 Extinguishant tank
- 6 Triggering cylinder
- 7 Transport seal
- 8 Pressure indicator for trigger line
- 9 Screw connection
- 10 Shut-off valve
- 11 Control cylinder adapter
- 11.1 Control cylinder manometer
- 11.2 Control cylinder pressure switch (4 A, 230 V AC, IP 65)
- 12 Protective housing

System

- ▶ Compact and attractive design, fitting into any kitchen.
- ▶ Suitable for subsequent fitting in extractor hoods, waste air ducts and automatic fryers.
- ▶ Cost-effective installation between working hours of the kitchen.
- ▶ Requires only minimum maintenance (service every 12 months only).

Installation

- ▶ Concealed installation of lines used for both fire detection and supply of extinguishant.
- ▶ The pneumatic actuation system does away with mechanical devices such as cables, pulleys, and expensive stainless steel frames.

Fire detection

- ▶ The fire detectors are mounted in front of the

grease filters and approx. 1.5 meters above the cooking appliances, detecting fires earlier than comparable systems by other suppliers, which in many cases is the decisive factor between limited damage and complete loss.

Extinguishant

- ▶ Febramax-S has been specifically developed for use in catering kitchens and is a hygienically harmless substance.
- ▶ Extinguishes promptly and leaves only minimum residue behind.
- ▶ Safe fire extinction thanks to double effect (cooling and separation effect).
- ▶ Quick extinction of the fire prevents serious damage.
- ▶ Kitchen can be reopened after short period of time, avoiding loss of earnings.

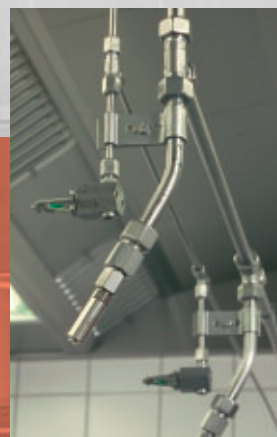

Easy and quick installation, cleaning and maintenance

The KS 2000 can be customised to suit any kitchen. As most of its components are pre-assembled, it can be installed between the working hours of your kitchen so that you do not have to close your business even for a day. Depending on your needs, the system is equipped with extinguishing nozzles that are mounted between 0.3 and 1.5 meters above the easily ignitable fat. The KS 2000 can thus be configured so that it does not in any way obstruct staff working in the kitchen.

If additional protection is required, you might opt for extra extinguishant by installing one or more secondary cylinders that are actuated separately.

The KS 2000 system must only be serviced once a year, further reducing the operating costs. After a fire, the KS 2000 is quickly restored to ready mode, protecting your property.

Unobtrusive safety

Thanks to its attractive design and compact stainless steel housing, the KS 2000 fits every modern kitchen.

Only available from Minimax – the pneumatic triggering system

The electric or pneumatic fire detection devices respond quickly and reliably as soon as the set activation temperature is reached.

Pneumatic actuation is the preferred solution for most kitchens, as costs for installation and operation are particularly low. Pneumatic

actuation also allows for the connection of any number of KS 2000 systems in series. Such solutions are recommended for kitchens where more fat and oil is heated than can be safely extinguished by small extinguishing systems. The KS 2000 allows for a broad range of pipeline layouts for concealed installation in every kitchen, irrespective of the size of the system.

Tried, tested and approved

Febramax-S extinguishant has been tested and approved by the official test institute for class A fires and fat fires. The KS 2000 has also been tested by the German trade associations of the food industry and is recommended for the use in catering kitchens and similar premises.



FUNCTION

KS 2000 COMPACT EXTINGUISHING SYSTEM

Equipment to be protected

- ① Waste-air duct
- ② Extractor hood
- ③ Grease filter
- ④ Frying and grill plate
- ⑤ Tilt frying pan
- ⑥ Cooker
- ⑦ Worktop
- ⑧ Deep fryer

Extinguishing system

- ⑨ Extinguishant supply unit
- ⑩ Extinguishant supply line
- ⑪ Extinguishing nozzle

Mechanical or pneumatic release device

- ⑫ Push button for manual actuation
- ⑬ Fire detection element
- ⑭ Triggering ripcord / pneumatic line

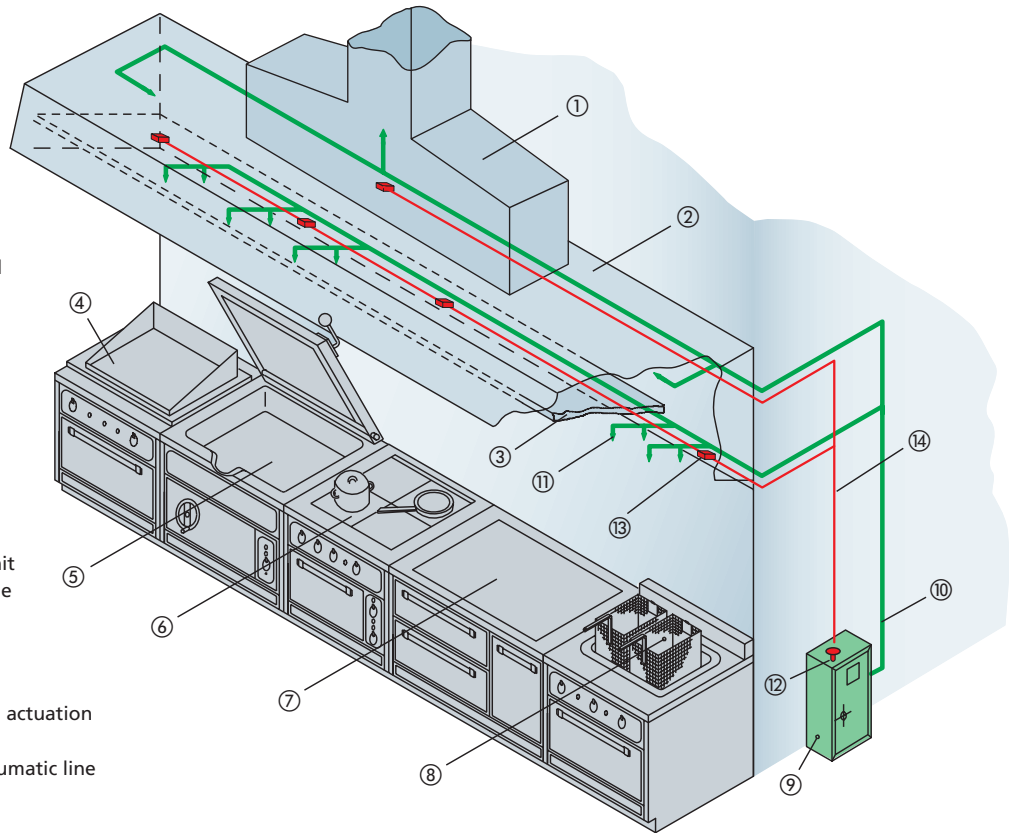

Dimensions of extinguishant supply unit	Extinguishant	Propellant	Actuation options	Number of nozzles	Supply lines and fittings	Fire classification
700 x 350 x 220 mm (H x W x D)	Febramax-5 (9 litres)	Carbon dioxide (70 g)	Pneumatic, mechanical, electrical and manual	Object protection: max. 7 Duct protection: max. 7	Stainless high-grade steel or equivalent material	Class A and special approvals for fat fires

mx BRANDBEVEILIGING

Member of the Minimax Group

Mx Brandbeveiliging B.V.
Televisieweg 62
1322 AM Almere
Tel.: +31 (0)36 54 61 60 0
Fax: +31 (0)36 54 61 61 0
info@mx-brandbeveiliging.nl
www.mx-brandbeveiliging.nl

Minimax GmbH & Co. KG
Industriestrasse 10/12
23840 Bad Oldesloe
Germany
Phone: +49 (0) 45 31 8 03-0
Fax: +49 (0) 45 31 8 03-2 48
E-mail: info@minimax.de
www.minimax.de

Nr. 5 89201
VdS
★ Certified acc. to
ISO 9001